



The Dalhousie Gazette
North America's Oldest Campus Newspaper, Est. 1868



Be Safe! Have fun!

Budget-friendly apartment décor, pg 14

Sand trucked to the waterfront, pg 16

Moncton drops out of football league, pg 17

Cover Photograph by Angela Gzowski

THURSDAY, SEPT. 15TH, 2011
GIRL TALK
ALDERNEY LANDING

TICKETS
ONLY \$25
+ FERRY FEE & SERVICE CHARGE

TIX AVAILABLE
ONLINE AT:
TICKETPRO.CA

DOORS AT 7PM
SHOW STARTS
AT 8PM SHARP!



THURSDAY, SEPT. 15TH, 2011
GIRL TALK
ALDERNEY LANDING



**DALHOUSIE
STUDENT
UNION**

DSU WEEKLY DISPATCH

Here is a list of upcoming events that you will want to mark your calendars for:

Dalfest

September 9-10

Come out to the DSU's official welcome back party! This event is full of games, live entertainment, free food, fireworks and of course a beer tent! There is also a FREE Bedouin Soundclash concert!!!

The Idlers will be playing the Grawood on Friday Night. This is a ticketed event so be sure to purchase your tickets at the Info Desk in the SUB or at the door! (This event is 19+)

Renowned DJ act The Killabits will be playing the Grawood Saturday Night at 10:00pm to finish off DalFest! This is a ticketed event so pick up your tickets at the Info Desk in the SUB or at the door (This event is 19+)

Be sure to check out www.dsu.ca for a complete list of event details or contact your Vice President of Student Life, Jamie Arron via email at dsuvpsl@dal.ca.

Society Fair

Wednesday, September 14

We will be hosting our annual Society Fair in the McInnes Room of the SUB. The event will begin at 11:00am and will finish up at 2:00pm. This is your chance to come out and meet new people with similar interests and get involved!

To register for a table please email Holly, your Society Coordinator at [HYPERLINK "mailto:society.coordinator@dal.ca" \o "blocked::mailto:society.coordinator@dal.ca" society.coordinator@dal.ca](mailto:society.coordinator@dal.ca).

Skratch Bastid does the Grawood

Friday, September 16

Internationally known DJ will be playing the Grawood for Feel Good Friday. The show is open to any Dalhousie faculty, staff, students and their guests who are 19+.

Advanced Tickets are \$5.00 at the SUB Info Desk or \$7.00 at the door!

Society Training Day

Saturday, September 17

Society Training day will take place on September 17th from 9:00am - 2:30pm in the McInnes room. This is a mandatory training day for all societies and at least 1 executive must be present.

You will find a registration form on www.dsu.ca under the Society Resources/Leadership & Involvement tab. Please complete this form and submit it to room 222 of the SUB by 2:00pm on September 14th.

Stay connected with the DSU through Facebook & Twitter

Facebook: Group and Page – Dalhousie Student Union

Twitter: www.twitter.com/dalstudentunion

September 2 - September 8, 2011 •

The Dalhousie Gazette

North America's Oldest Campus Newspaper, Est. 1868

staff

Dylan Matthias, Editor-in-Chief
editor@dalgazette.com

Erica Eades, Copy/Arts Editor
copy@dalgazette.com

Katrina Pyne, News Editor
Torey Ellis, Assistant News Editor
news@dalgazette.com

Leilani Graham-Laidlaw
Opinions/Online Editor
opinions@dalgazette.com

Leslie Gallagher, Assistant Arts Editor
arts@dalgazette.com

Ian Froese, Sports Editor
sports@dalgazette.com

Angela Gzowski, Photo Editor
photo@dalgazette.com

Jenna Harvie, Creative Editor
creative@dalgazette.com

Jonathan Rotsztain, Art Director
design@dalgazette.com

Ben McDade, Business Manager
business@dalgazette.com

contact us

www.dalgazette.com
The SUB, Room 312
6136 University Avenue
Halifax NS,
902 494 1280

Advertising Inquiries
Aaron Merchant, Ad Manager
902 449 7281
advertising@dalgazette.com

the fine print

The Gazette is the official written record of Dalhousie University since 1868 and is open to participation from all students. It is published weekly during the academic year by the Dalhousie Gazette Publishing Society. The Gazette is a student-run publication. Its primary purpose is to report fairly and objectively on issues of importance and interest to the students of Dalhousie University, to provide an open forum for the free expression and exchange of ideas, and to stimulate meaningful debate on issues that affect or would otherwise be of interest to the student body and/or society in general. Views expressed in the letters to the editor, Overheard at Dal, and opinions section are solely those of the contributing writers, and do not necessarily represent the views of The Gazette or its staff. Views expressed in the Streater feature are solely those of the person being quoted, and not The Gazette's writers or staff.

This publication is intended for readers 18 years of age or older. The views of our writers are not the explicit views of Dalhousie University. All students of Dalhousie University, as well as any interested parties on or off-campus, are invited to contribute to any section of the newspaper. Please contact the appropriate editor for submission guidelines, or drop by for our weekly volunteer meetings every Monday at 5:30 p.m. in room 312 of the Dal SUB. The Gazette reserves the right to edit and reprint all submissions, and will not publish material deemed by its editorial board to be discriminatory, racist, sexist, homophobic or libellous. Opinions expressed in submitted letters are solely those of the authors. Editorials in The Gazette are signed and represent the opinions of the writer(s), not necessarily those of The Gazette staff, Editorial Board, publisher, or Dalhousie University.



Meet Haligonians Ben Ur and Rieka Santilli who would love to hear you cheering them on at the Tigers' soccer home openers!!

BACK IN ACTION!

SATURDAY, SEPTEMBER 10
Soccer Home Opener vs. UPEI, W 1pm, M 3:15pm

SUNDAY, SEPTEMBER 11
Soccer vs. MtA, W 1pm, M 3:15pm

RIEKA SANTILLI Defense/Centre Midfield
Program: Commerce, 4th year
Favourite Dalhousie class: Beginner Italian
Favourite pro athlete: Fabio Cannavaro
Biggest rival school: St. FX

BEN UR Keeper
Program: Arts, 5th year
Favourite Dalhousie class: History of rock and roll
Favourite pro athlete: Petr Cech
Biggest rival school: SMU

Webcasts are available at www.ssnCanada.ca



Admission is FREE for DAL students with ID

WWW.DALTIGERS.CA

FOLLOW US ON FACEBOOK & TWITTER

from the editor

from the editor

E-mail Dylan at editor@dalgazette.com

Dylan Matthias Editor-in-Chief



A note on class etiquette

Why you shouldn't submit late editorials

Dylan Matthias
Editor-in-Chief

So last week, we told you how to fight zombification at Dal. Looking back on it, while this was sage advice, it might not have been what you needed right this instant. And we in the news business are all about right this instant—constant gratification, they tell us, is all the rage. Check us out on your mobile phone.

But wait! Frosh week, summer and its constant, live-updating, photo-sharing, interconnected-intercommunicative ways are pretty much over. You spent yesterday sitting in the Life Sciences Centre and it really is that stuffy pretty much all the time. You have three months or so of this to go, it seems like forever, and you're longing for a chance to check your new friends' latest photos.

On the other hand, you're in class,

and they're not—curse your unwieldy, irregular university course schedule. This isn't high school: you have at least one inconvenient evening class. You have to manage time now. The insane tuition you just out found about is calculated from your classes, so you may as well do well in them. That's why you're here.

So in the tradition of offering sage advice from your campus paper (for more, see our staff bios and pretty much the rest of the paper), we'll help you through this. It's actually considered politically informed to be reading a newspaper before class, whereas checking your cellphone—even checking your newspaper on said cellphone—is the height of rudeness. Do not do this, and do put the Gazette away when your prof goes to the front of the room. We don't like the guilt on our minds.

You will, by now, have received a

list of textbooks and/or a syllabus. These are important documents, so read them. Then buy the books—all of them, used or new—and read them, too. Read the course schedule and find at least one lecture to look forward to. Read the blurb on plagiarism and then read our article on what that really means and why it matters on page five.

Reading is what universities are for, it's how they started and it's how they still work. It's traditional in the 19th-century-was-cool sort of way that we're all about here. If you go to King's, you understand.

Universities have been asking questions since time immemorial, and so has the *Gazette*. Students started this paper when they wanted a place to discuss philosophical and scholarly issues. Old questions are on display in our archives, both online and in the library. Your job now is to try to

think up new and better ones. It can be tough to do this and then speak up in front of a large class. Try it anyway. Profs do not eat that many students per year, so the chance it will be your question that sets them on a spree is relatively minimal. And your classmates appreciate your courage, bravery and dedication to the public good, as great Nova Scotian question-asker Joe Howe would perhaps have said.

At some point in the great institutional practices of both journalism and academia, coffee became an essential tool in our work. It is important to remember, as we all embark on another year of long classes, that coffee is not a substitute for food. Eat breakfast before class, and if you have a long day, eat lunch, too. Coffee can help—ask our news editor on page ten or just about any grad student. There is nothing harder than going to class hungry.

Last of all, if you must learn something from this editorial: submit work on time, be it for the *Gazette* or your classes. Writing editorials or essays at the last minute is not fun. Prepare, and at least think of a topic before you dive in. If you need an extension, follow the *Gazette* procedure: ask for it well in advance, when you know your editorial will be wildly late. Profs and copy editors both appreciate knowing in advance.

We've provided twenty pages of procrastination this week, all free of charge, with plenty of diverting content. Take a break, read us, then go back to Middlemarch. It is long, we know, and we sympathize, but your mind will work better after a foray into journalism and some coffee. It all asks questions, and you'll need those when that first essay comes around much, much faster than you think it will. ☹

SKRATCH BASTID

Feel GOOD FRIDAYS

SEPTEMBER 16TH, 2011

the GraWood Est. 1972

FOR PEOPLE WHO LOVE WICKED LIVE MUSIC

Open to Dal Students, Faculty, Alumni and Guests

Advance Tickets \$5 / \$7 Door / Doors at 9pm

Tickets on sale at the information desk 16136 University Ave Student Union Building

English Department Distinguished Speakers Series

Dr. Robert Scholes
(Brown University)

“Teaching and Clowning as Modes of Performance”

Thursday, September 15th 2011
7 to 9 PM

Scotiabank Auditorium - McCain Building

Sponsored by

50 Grads. One Weekend. Your Future.

We're inviting 50 of Canada's top engineering students to Waterloo for one weekend to plan their futures.

All expenses paid.*
Want to join us?

The 50 Graduates Weekend is a chance for selected Canadian students interested in master's and PhD studies to learn about graduate programs in the Faculty of Engineering at the University of Waterloo and experience life in one of Canada's most vibrant communities.

You will tour state-of-the-art engineering facilities, explore innovative research programs, and learn about collaborations with the region's growing list of technology, automotive, financial, health and environmental companies.

You will also get a taste of the region's exciting social life with visits to local cultural centres, restaurants and the idyllic village of St. Jacobs.

It's happening
November 3 to 6, 2011

Apply at:
engineering.uwaterloo.ca/50graduates
Apply by: **September 30, 2011**

WATERLOO ENGINEERING

*Details regarding travel expenses can be found at: engineering.uwaterloo.ca/50graduates





Katrina Pyne News Editor

A word from your presidents

The issues of last year and a look to the future

Katrina Pyne
News Editor

Q: What changes will students notice on campus this year?

Tom Traves, president of Dalhousie University: More students on campus. We have more international students on campus, so [there will be] a much more diverse and vibrant environment, which we're excited about.

Chris Saulnier, president of the Dalhousie Student Union: More emphasis on welcoming students back to campus. We want to make sure we encourage students to continue to be involved after Orientation Week is over, and not just fall into classes.

Q: What are the top three issues on campus to look out for this year?

TT: 1. We are in discussions with the government about funding arrangements for next year, which include not only the government operating grant but the level of tuition fees that

we will charge to students. 2. Merging the Nova Scotia Agricultural College in Truro into Dal. We expect that to come to fruition in the fall of 2012. 3. Improving the level and kind of student services we have available on campus. More supports for international students, to make sure that they acclimatize to studying in a Canadian environment.

CS: 1. Parking. 2. Tuition fees and government funding to universities. 3. Watch out for changes in level of service because obviously in these financial times where the university is seeing their budget shrunk, we are starting to see some services have less funding and less support provided.

Q: What is the first item on your list of priorities?

TT: Frankly, the most significant development for us is in the immediate term is our merger with the Nova Scotia Agricultural College because that will create a new Dal campus and a new range of academic pro-

grams here. From a long-term perspective, this will be important in the history of the university.

CS: Simply communicating with students. Finding new and effective ways to communicate with students on the issues that we are working on and the issues that will affect them in the future. I will be working closely with the Board of Governors to try to establish some guidelines around what consultation should look like.

Q: What are the top issues for students to be following to affect change?

TT: Students are obviously always concerned about tuition levels. They need to be engaged to understand the financial challenges the university faces, particularly in a period where the government is cutting grants to the universities and the two major sources of funding for universities are government grants and tuition fees. So I think it's important for students to engage in that issue and speak their minds about this not only

to the university but also to the government. Students have a big stake in that in a very practical way.

Q: What are some big changes that occurred over the summer?

CS: There's the big win for us with the learning disabilities support specialist, Neera Datta, coming back to campus. Also in the past, Orientation Week for international students has occurred during the StudentsUnion's Orientation Week, so they've had to choose which orientation week they wanted to go to. But this year we moved the international student's Orientation Week so they can attend both. Also, SeeMore Green is moving their garden to behind the Computer Science Building. Students should check that out.

Q: What is it like working with the DSU and Chris Saulnier?

TT: Chris is a very effective spokesperson for the university. He has the advantage of a year's experience, so

he understands the issues and processes and structures of governance in a university and he did very well with that last year. So I have a lot of respect for him and I listen carefully when he says there's an issue that needs to be addressed. I don't sweep that under the rug.

Q: What is it like working with Tom and the Dal administration team?

CS: It's really nice working with Tom. He actually does come from a student union background. He was on the exec. of his student union in his undergraduate degree so he does have an understanding of the issues that we are facing and the context that I work in. We both want Dal to be a very well respected and very good institution, and we might not always agree on how to get there, but we both know that at the end of the day, we are working towards the same goal. **Q**

Professor quits over lack of parking

Dal's ongoing issues with parking spaces reach a boiling point

Torey Ellis
Assistant News Editor

After 30 years of teaching, Dalhousie professor Dan Middlemiss quit his job this month over the school's lack of parking spaces, saying the problem isn't specific to Dal.

Last year the Dunn parking lot was oversold by 915 parking passes, according to Samantha Chown's article from the *Dalhousie Gazette* archives.

This year, spaces will only be oversold by 20 to 30 per cent. New short-term parking meters will also be added.

Middlemiss, a professor of political science, resigned on Aug. 29 after waiting an hour and a half in line for a parking pass. He was turned away and told to come back the next day. "It was a Monday spur of the moment decision after 30 years of frustration," he says.

"I didn't start out to make this a crusade against Dal or against anyone else. This is a problem that is endemic to the whole region. And it's getting worse. There are just more and more people coming in."

The new parking system makes the Dunn parking lot, between Fountain House and the Dunn building, a reserved lot with more expensive passes in hopes of decreasing demand on spaces. A draw eventually decided the recipients of these passes.

"I felt a bit sheepish afterwards," he says. Through the media attention, his story has led to outpourings of support from as far away as South Africa. But there have been a few nay-sayers.

"There are some that are not so positive," he says. "They say, 'poor

privileged professor'—and completely rightly so."

Middlemiss acknowledges that he had an option that few other commuters do. He says some, like his secretary, waited in line for four hours without receiving a pass.

"It was an outburst of frustration, but I at least have an option. I feel sorry for my secretary and other staff and students, who are all trying to get these spots."

Dalhousie's Master Plan, which outlines the rejuvenation of all three campuses over the next ten years, includes plans for decreasing the volume of traffic by encouraging bike and transit options.

"If only it were that simple," says Middlemiss. Living in Lower Sackville, a one-way bus trip takes approximately two hours and biking down two highways is not an option.

"To be fair to Dal, it's not their problem and they've been very forthright about all this," he says. Middlemiss sees the real problem as Halifax's transit system, which he says would benefit from a more direct route to universities, and an influx of cars from drivers living close to work or school.

"If I lived around the university I'd take transit. It's getting to the core that's the problem," he says.

Dalhousie's Master plan is against the creation of large parking facilities, in the interests of sustainability and decreasing commuting. It argues that "urban campuses" often see a decrease in numbers of commuters, as other options become available and the cost of driving increases. **Q**



.....
"This is a problem that is endemic to the whole region. And it's getting worse."
.....

This year, parking spaces will be oversold by 20 to 30 per cent. ••• Photo by Torey Ellis





Please take good care of yourselves. ••• Photo by Angela Gzowski

FIGHTING THE FRESHMAN FIFTEEN

WHY THE TRADITION OF WEIGHT GAINS HAS HELD FAST

Sean Gallagher
News Contributor

In Risley Hall's cafeteria, a steady stream of students bearing plates crowded with fries, hamburgers, pizzas and not much else is a familiar sight.

But although some students avoid healthy selections, those options are available. Third-year commerce student Samantha Lush recently completed a work term with Aramark, Dal's on-campus food supplier.

"Aramark makes it a priority to provide students with a wide range of healthy and nutritious meal options. It is up to the students to employ those options," she says in an email interview. Lush praises the effort that the national supplier puts into its menu and service.

For many first-year students, proper nutrition is the last thing on their minds. Their new freedom, combined with a decrease in physical activity, acts as a swift punisher to belts and skinny jeans across the nation.

Chantal Gautreau, a third-year psychology student, remembers her first year in Howe Hall. "I had this idea that I had already paid \$3,000 for my unlimited meal plan, so I might as well make the most of it," she says.

"I stocked up on whatever I felt like. I even saw some other students sneaking cake into Tupperware con-

tainers hidden in their purse."

Fifteen pounds may be an exaggeration. The average student will gain three to ten pounds in their first two years at university, according to kid-health.org.

But the saying, "freshman fifteen," makes an important point that inattention to types and quantities of food consumed has consequences. For instance, a whole grain raspberry muffin from Tim Hortons has more calories than a medium fries at McDonald's (400 vs. 360), yet Tim Hortons is often considered the healthier option.

Reading nutritional labels and understanding Canada's Food Guide are vital to a healthy body. It recommends that students eat seven to ten fruit and vegetable servings per day; many students consume half of that on a good day.

Angela Emmerson, Dal's on-campus dietician, says students confused about nutrition are free to contact her at dietician@dal.ca. She advises students opt for lots of vegetables, salads and lean proteins when selecting meals. "You should be filling half your plate with vegetables, ideally," she says.

She says a student's best weapons against the battle of the bulge are Health Canada's Food Guide, regular physical activity, and a little bit of self-control. ☺

Turnitin turned off

University temporarily walks away from anti-plagiarism software

Katrina Pyne
News Editor

For many students, it's a dream come true. But for many staff, it's a nightmare. Dalhousie walked away from renewing its contract with Turnitin, a plagiarism-checking service, after claiming the company had broken the trust factor.

"The trust factor was less than we assumed it to be."

Dwight Fischer, assistant VP of Information Technology Services at Dalhousie, made the final decision at the 11th hour on August 31 as the contract ended, sparking much controversy.

"We knew we had an issue in June. We have colleagues across Canada who use the service as well and we found out some things about how the company was operating that we questioned," says Fischer. "We found some elements of our relationship with them that led us to believe that the trust factor was less than we

assumed it to be."

In a recent CBC article on the issue, it was put forward that the cause of the broken trust was that the Dal IT team found out that the data on Turnitin was being stored in the United States. In the past, it has been suggested that data stored in the United States is therefore subject to the United States Patriot Act.

"That is not the issue though," says Fischer. "We are moving in that direction anyways. It's not because [Turnitin] was storing stuff in the States. It has to do with the integrity of our process with the contract."

According to Fischer, only 29 of the faculty members at Dalhousie were using Turnitin to begin with, mostly in the Faculty of Arts and Social Sciences.

He says they threw them a bit of a curve ball by walking away from the \$20,000 Turnitin contract, but suggests that there are still alternatives to check for plagiarism for the time being.

"Faculty can just take segments of papers and Google them. You'll find out rather quickly where stuff is, if it looks suspect," he says. However, the time involved to Google each segment of an essay would put a lot of pressure on faculty, and would likely prove to be far less effective than a

Turnitin substitute.

"I don't think it will have that much of an effect on students," says Nick Little, a third-year neuroscience student.

"I think it will be a hell of a lot more difficult for [professors] to determine whether it's plagiarism from other sources."

Still, Dal's official line is that it is looking for alternatives. Fischer says that Blackboard, a learning management system, is being looked at very closely. However, even Blackboard fails to compare to the much larger Turnitin database.

Chris Saulnier, president of the DSU, says we should take this time to reignite the conversation on whether a plagiarism-checking service is the right direction. For years, faculty and staff have taken issue with Turnitin, due to the loss of intellectual property and copyright issues.

"Students don't get to keep their work as their intellectual property that they produce in their degrees," he says.

Fischer says it still comes down to students. "What message are we sending? The message is that we have an academic integrity policy and you see it on every syllabus. Everybody is still accountable." ☺

••• Photo by Katrina Pyne



Blogging through death camps

A student's journey through the Holocaust

Laura Hubbard News Contributor
Katrina Pyne News Editor

This past May, sixty Canadian students traveled to Germany and Poland on the March of Remembrance and Hope, a Holocaust case study program that works to embrace diversity and eliminate genocides and hatred through the Canadian Centre for Diversity.

Laura Hubbard, a third-year student of the University of King's College, was chosen to take part in the March, one of two participants from the Maritimes who attended.

Hubbard writes her thoughts and experiences in her blog, chronicling her journey through some of the most infamous destinations in history.

Two survivors, Pinchas Gutter of Majdanek Extermination Camp, and Faigie Libman, a survivor of Birkenau, travel with the group, sharing their stories and experiences, inspiring others to stand up for Holocaust education and human rights, and continue to do so when the survivors are gone.

"I can't say I've been to hell," she writes in one entry. "Not in comparison to the stories we heard while overseas and the stories and facts we all know about the Holocaust. It's not fair to compare my suffering now, as I deal with society and humanity, to the suffering then. It's minimal in comparison."

"But I can say I survived Auschwitz. I survived Majdanek. And that's rare. It's fantastic that I could visit these places and have the opportunity to witness the sites and atrocities to further educate and prevent genocide. But it is hell, and I was there. I witnessed it too."

While in Europe, students traveled within Berlin and throughout Poland, visiting sites such as the Wannsee Villa, where the Final Solution was planned, Auschwitz, Treblinka, the village of Tykocin, and many memorials, including the Umschlagplatz in Warsaw, and Babelplatz—the site of the book burnings in Berlin.

She describes the trip as "fantastic, but emotional and exhausting."

Since her return, Hubbard has continued to write about her experiences.

A few weeks after her trip, she blogged about this reflection process. "I'm carrying on daily life as if normal, with my thoughts running through my mind. I've yet to openly talk about my experiences, my thoughts, my struggles."

"Majdanek was hell on Earth and it still is, today. For the most part, Majdanek is as Majdanek was. And that made things real. That gave me goosebumps. And that really showed the hell. The reality of it made Pinchas' story come to life and haunt me. It is this place that is the epitome of evil and fear and horror in my mind. And it is this place that is in my mind so often during the night as I dream."

During a trip to Majdanek, Hubbard walked past 20,000 pairs of shoes, taken from those entering the death camp by Nazi guards. She writes, "I can't relate to a number. I've never seen six-million of something."

But when she saw 20,000 pairs of shoes the numbers began to sink in. "I couldn't believe the amount. And the smell of the hot leather, the stale air in the barracks. This was powerful."

Students visited Majdanek on day five of their trip. Majdanek was the site where survivor Pinchas Gutter was sent for the majority of his childhood in the Second World War, making the visit back even more meaningful for Hubbard, as he shared his story, and remembered walking the same paths.

It wasn't until Hubbard was flying over Majdanek on the way home that she was able to write a journal entry about the visit. Her blog post the day of the visit was brief:

"This [memorial at Majdanek] was so powerful and emotional for me: we all truly shared a connection—the same cause. We were not only honouring those whose ashes were in front of us, but those who were brave, strong, and hopeful. The past, present, and the future." ☹

Laura's blog can be found at www.pilgrimagetopoland.blogspot.com. It charts her journey overseas and deals with the emotional and educational aftermath and reflection process.



Auschwitz, Poland. ••• Photo by Laura Hubbard

One Night

One night, past November
a quiet shadow sat still,
frozen in the chilled air,
her shoulders shrunken and legs
dangling
over the balcony banister
and she hummed a tender melody,
singing along with the
whistling branches.

On a day without a date,
she lolled her head
with the swift night breeze
and remembered the smell of fresh
lilies.
His fresh pink lilies.

But like the soft scent of
those favourite flowers,
his memory faded too
and she was left in the cool air,
her mentality slipping off with the
passing wind, on that calm night
past November.

—Jenna Harvie

The Painting

In my secret playground,
far from Mother's sight,
I came across a painting,
tucked behind a worn bureau.

With simple curiosity
I blew dust from its cool surface
and studied the father figure,
familiar, yet distant.

Drawn to its static design
and flawless brushstrokes
I stowed it atop by desk
next to another, of my mother.

But on one quiet August day
she came in to find a painting
and a photo, sitting comfortably
side by side.

Without another blink
I held my cheek in a sweaty palm.
As she left, memory in hand,
she choked out a delicate phrase
about my father's suicide.

—Jenna Harvie; Inspired by the
poem *The Portrait* by Stanley Kunitz

Inside

I stare at you
watching without care
soon I will be through,
out from my murky lair.

I'll crawl through this door
and touch your silky skin,
drive my soul into your core
until I'm the one within.

Your pretty eyes
and perfect complexion
make my blood rise
from within your reflection.

It's time for your body
to come through,
for your skin to bleed,
because my dear,
I've waited this long;
I am escaping.
No longer will I be the one
inside this mirror.

—Jenna Harvie

SUBMIT YOUR
MICRO-FICTION & POETRY:
CREATIVE@DALGAZETTE.COM

sudoku

8	7			1				
					2	3		
1				2	4			
				9		2	7	
5	9	3						
			1	8				6
4	1	9	6				7	
	5	7	9			1	6	
			2			5		





Consent and radical vulnerability

No, yes, hell yes and everything in between

Hayley Gray
Sex Columnist

We've all been notified, one way or another, that individuals are supposed to consent to sex. In theory, we all agree. In practice, consent often becomes shades of grey instead of a black and white yes or no. In university especially, consent is often presumed. I don't consent directly to every sexual encounter, and I have not explicitly asked for consent every time. In theory, I would explicitly ask for consent every time I have sex. But in practice, my consent models are a little more fuzzy.

One way individuals slide consent into their sex lives is by asking questions: I can remove clothing, get a condom, touch a place, etc. This form of consent is consultational. Its power lies in being able to continuously check in with your partner while keeping things casual. This is a model where individuals must actively consent, where sex only happens when there's a "yes." It is also the model that many activists advocate for, including Jacklyn Friedman, the author of *Yes Means Yes*. Friedman goes beyond consultational consent to enthusiastic consent; not just a "yes" but a "HELLS YES!"

This type of active consent can be

a huge turn-on, hearing how much someone wants you, telling someone how much you want to be with them, in them, around them, on them – whatever, it's sexy. It's hot to hear enthusiastic consent spoken to you by your partner, so why is it that there is still so much non-consensual sex on college and university campuses? September and October see the highest rates of sexual assault in North America. In Canada, the highest rates are in Nova Scotia and in university-aged women.

These are intense and complex problems that we are constantly striving to address on our campuses. These problems are based on a myriad of social dynamics. Two issues that come up again and again when addressing sexual assault are power and vulnerability. In university (and the world beyond) individuals often attempt to exert their drive to dominate, to control, to have power over others. In the hook-up culture, individuals keep their power by exerting disdain and aggression to the individuals they engage with sexually.

To keep power, they must be less interested in their hook-up partner than their partner is in them. This strive for sexual power leaves many feeling used, disempowered, hurt or uncared for. It is interesting and terrifying to see how these power strug-

gles have shaped hook-up culture to be a competition between yourself and your lover.

So why compete? Why not acknowledge your partner as an amazing individual who you can't wait to jump into bed with? Consent is scary. It involves the vulnerability of telling someone that you want them, and even scarier, asking them if they want you back. You're asking for permission to be vulnerable and see your partner's vulnerability. That's terrifying. But without it, you end up making assumptions, trying to control someone else or striving for aggressive detachment.

Brene Brown, a research professor at the University of Houston, found that individuals who had a strong sense of love and belonging and who were able to meaningfully connect with others shared a common trait of fully embracing vulnerability.

You're in university. You're figuring your shit out, defining and redefining yourself, and falling in and out of love. You're fucking vulnerable. Next time your feeling that intense and terrifying sense of vulnerability build up your empathy instead of your defenses. Assume your partner is feeling just as vulnerable as you. Take your sense of vulnerability as a sign of mutual empathy. After all, we're all extremely vulnerable. ☹



Would you fuck him? ••• Illustration modified via briarpress.org

Rethinking student aid administration

To fax or not to fax (you don't have a choice)

Ben Wedge
Opinions Contributor

By and large, Canada's student loans programs work. Aid is being provided to those in need. There are small groups of students who aren't getting enough, and there are small groups of students getting way too much, but that's not the point of this article—the point is method, not size.

Businesses are discovering revolutionary technology, such as email and web forms, all over the world, and the smart money's moving away from business models that involve re-processing and poor customer service. Unsurprisingly, and rightly so, student loan offices are not businesses, or at least not in the "make money and pay taxes after providing goods and services" sense. But they certainly have a thing or two to learn.

Take, for example, the Ontario Student Assistance Program (OSAP). They have convenient office hours (8:30 a.m. to 4:30 p.m., Monday to Friday) which are perfect for students in dire need of help—those who couldn't find a summer job. Students who have found work during business hours but aren't being paid enough to make ends meet in the fall are out of luck. They could call during their lunch breaks, as OSAP's phone system is, after all, advanced enough

to tell you the expected wait time and the number of students ahead of you in the queue. Once you get through to their phone agents, they listen to the issues, pull up your file, and tell you to fill out a form. Then you roam your city for a working fax machine to send the information to someone else, who will spend more time re-considering the information you have already provided.

They have made progress in providing web-based service, but often require you to fill out information, such as your name and birth date, which already exists in their system. Logging in is another issue, since you must enter an arbitrary identification number rather than an email address or username that would be easy to remember.

I can't make this up. I really can't. My girlfriend wasn't able to click "single, never married" on her initial OSAP web application this summer, because the option wasn't there. The closest? "Separated." After two days of calling, she managed to get through, no doubt eating up all of her cell phone minutes for the month. The agent pulled up her file, presumably on a computer, and asked her to fax a letter in identifying the problem. In this age, how could the agent not just change her marital status immediately?

Stewart Rand, a recent graduate of Dal's computer science program, pointed out another huge deficiency with this slow-poke model of loan administration: the Nova Scotia Student Loans program is obsessed with paper and letter mail. The time and money spent on paper, re-typing forms, and mailing them could certainly send dozens, if not thousands more students to school comfortably every single year.

Bethany Horne, a former King's student and *Gazette* editor, concurred in a recent discussion on loan processing, herself a victim of OSAP's poor administrative practices, particularly their inability to deal with students who are not studying in Ontario.

Our student loan system should look at how much is being spent administering the loans. Re-processing, poor customer service, and paper/mail/faxes have largely been eliminated in the private sector because they take time and money that could otherwise be used to provide better goods or services, or to cut costs. Our student loan programs need new management, with an eye for efficient delivery of services, hours that suit students, and a focus on getting more of the already-allocated money into the hands of students. ☹

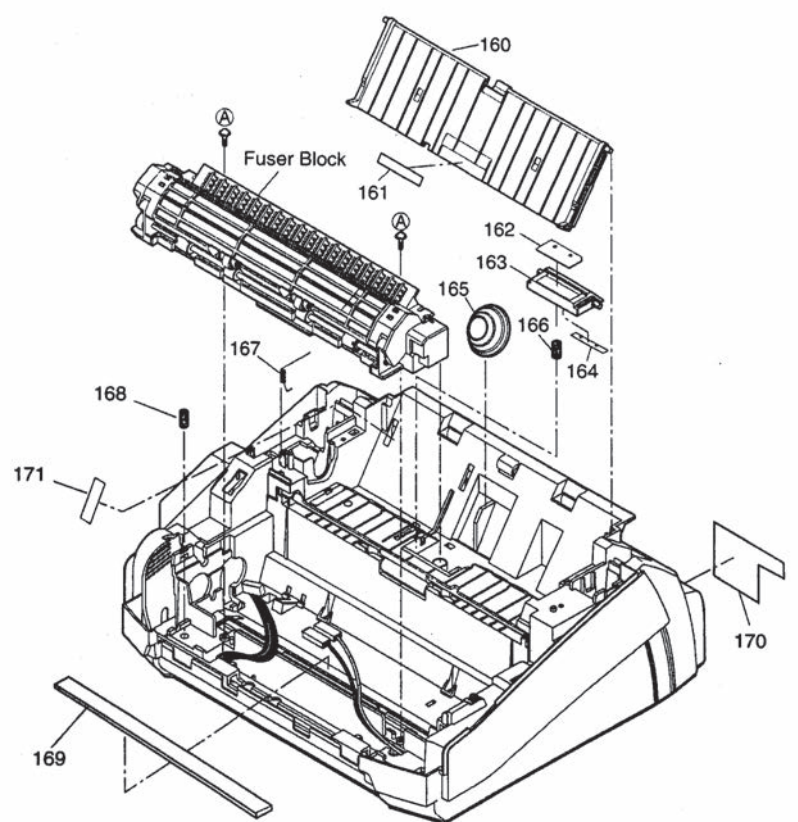

As simple as that.

••• Illustration via Panasonic Fax #KXFLM551 machine instruction manual

FOLLOW US ON
twitter 
@dalgazette **@gazette_arts**
@gazetteopinions **@dalgazettesport**





Brand not books! ••• Photo by Ian Froese

Satire: Dal's bookstore

A model of efficiency for 21st century schooling

Nick Wright
Humourist

While certain reactionary bourgeois elements on campus are fighting the good fight to clean up the excessively intellectual nature of university life, all may not be as bleak as it seems. Cradled in the basement of the otherwise socialist Sodom and Gomorrah of the SUB, lies a bastion of hope. I speak of course of the Dalhousie bookstore and its truly 21st century approach to education.

Before even entering the bookstore one cannot help but marvel at its ingenious commercial tactics. Literally standing sentry at the front door

are guards whose job consists of having students leave all of their personal belongings at the door. This not only cuts down on shoplifting, which the management might expect given the outlandish prices they charge, but also helps business when students are required to buy an entire new set of school supplies to replace the things that have been stolen. The management has of course covered all bases by posting visible signage stating that they will not be held responsible for the inevitability of stolen belongings.

Once gaining the privilege of actually entering the bookstore, you are made immediately aware of one thing: there is not a book to be seen.

Having realized that print media is a dying art the bookstore is cleverly looking to the future. For this reason the majority of the floor space is devoted not to these archaic relics but to Dalhousie brand merchandise.

Should one actually be there for the purpose of buying textbooks, one will be able to find them once through the extended gift shop section of the store. The books themselves are kept exactly where they should be in any establishment of higher learning: a closet like space at the very back. Here one will find all sorts of incredibly overpriced textbooks and required readings for every course offered during the semester. The exorbitant price

of books would normally be an issue for any other business but having a near perfect monopoly on Dalhousie textbook sales in town, the bookstore is free to set whatever prices they wish.

Organization is another feature to be commended. Sections are organized by department and class number. One will not find a single extraneous volume. Should anyone wish to find any other books pertaining to their field of study, the Dalhousie Book Store is not the place for them. This is a practice which is actually implemented in other forms all around the university and works by offering exactly what is on the cur-

riculum without actually fostering an atmosphere of learning. It is a truly ingenious philosophy which sends a strong message that all learning to be done is best done through official channels as well as making it clear to agitating book-reading types that this is not a place for them—this is a place to buy sweatpants.

Truly, the bookstore is a shining metaphor for Dalhousie itself. A place which makes students shell out far too much money for things they are mandated to need, entices them to spend more on things they don't, and in the end leaves them with nothing of substance. ☹



Vive l'Acadie.

••• Photo by Makaristos via Wikipedia

Faut-il écrire en anglais?

Would the Francophiles at Dal please stand up.

Leilani Graham-Laidlaw
Opinions Editor

Près de la Moitié de cet article est en Français. Très différent, pour nous à la Gazette. Mais en un de 36 pays officiellement multilingue du monde, avec un population Français pas si petit à Halifax, pourquoi est notre journal uniquement en anglais? Seulement 59 pour-cent des Canadiens parlent anglais naturellement, faible majorité. Voulez-vous écrire, ou plus

important encore lire, les articles en Français publiés ici?

Pour soumettre un article, discuter de la situation du Français en Halifax ou de défendre la anglicité de la Gazette, cliquez sur www.dalgazette.ca/oped.

If none of the above made sense to you, a brief gist: This is Canada. We are a bilingual country and have a fairly decent French-speaking population here in Halifax. Shouldn't this

paper also publish articles written in French? Why or why not? What about other languages? For all those francophobes or francophiles out there, if you've got something to say on or en Français, check out www.dalgazette.com to discuss or submit articles. ☹

Welcome back students!

Join us for **Tapas & Taps Hour**
4:00pm-6:30pm daily



Fine food, fine brews,
in the heart of Europe!

446.4700 • BrusselsRestaurant.ca
1873 Granville St., Granville Square

@HamachiHouse
Lovers of Hamachi

welcome home to
Hamachi "Best Sushi"
for the past 8 years.



Happy Maki hour daily
from 10pm to 12am

425.7711 • HamachiHouse.com
5190 Morris St., Halifax, Nova Scotia



STUDENT SPECIAL



**STUDENT'S RECEIVE
ANY REGULAR PRICED MENU ITEM
50% OFF**
MUST SHOW VALID STUDENT ID. NOT VALID WITH ANY OTHER OFFER

PLUS THESE GREAT OFFERS EVERY WEEK!

**MEGA
Monday**

One large Pizza with
4 single toppings
\$10.99

Mention Code: 4202 Valid on Monday only



2x Tuesday

Buy any Pizza at
regular menu price &
get a second Pizza of
equal or lesser value

FREE

Mention Code: 8521. Valid on Tuesday only.



**Wacky
Wednesday**

One medium
1-topping Pizza
\$5.00
EACH

Min. order of 3 for delivery.
Mention Code: 3008. Valid on Wednesday only.



902-420-9999 6112 Quinpool Rd.
(Vernon Street) Serving Halifax Peninsula and Fairmont

902-444-9999 480 Parkland Dr.
Serving Clayton Park, Fairview, Kingswood and Bedford (South of Hammond Plains Rd.)



*Double portions, premium toppings and extra cheese are subject to an additional charge. Coupons are not valid with other offers. Copyright Domino's Pizza of Canada Ltd. Products may not be exactly as shown. Limited delivery area. Delivery charges may apply. Drivers carry less than \$20. Prices subject to change without notice. Applicable taxes not included in advertised prices. © Trade-Mark of Interac Inc. TD Canada Trust authorized user of the Trade-Mark or Trade-Mark of Interac Inc. Used under license. Offers expire May 1st, 2011.



Dylan Matthias
Editor-in-chief

Dylan is beginning to worry that he's been around the Gazette too long, mostly because he's now been roped into running the paper for all of the 2010-11 year. He's a fifth-year student trying to do English, journalism and creative writing all at the same time. In his (diminishing) spare time, he covers university soccer on various blogs and writes speculative fiction novels on such themes as death, power and political corruption. He enjoys contradictions and wishes time-travel existed right now. He ran a high school paper called *The Wall* for two years in very rural Nova Scotia, and he now realizes that stress then has nothing on stress now. Drop by the office to chat, eat leftover pizza, or volunteer. This paper's important, and everyone's in this together—otherwise Dylan probably would have found something better to devour his time by now.



Erica Eades
Copy Editor/Arts Editor

Born in the small town of Almonte, Ont., Erica developed an appreciation for the arts at a young age. Her childhood was filled with drama classes, piano lessons and art camp, and during her free time, you could find her curled up reading in a comfy chair, or working on her next great literary masterpiece (the first being "The Baby Dragons," a short story written at age six about the joys of friendship and Polly Pockets). Erica later settled in Halifax to begin her degree at Dalhousie University. Initially studying international development, her childhood love of reading and the arts motivated her to switch degrees and pursue a major in English with a minor in journalism studies. She began writing for the *Dalhousie Gazette* in 2009 and moved up to assistant arts editor in 2010. Now she'll be taking on a more substantial role at the paper as both arts editor and copy editor. Erica has big shoes to fill this year, but she brings with her a solid grasp of the English language, and a desire to further the paper, whether that's through increasing readership, offering top-notch arts reporting, or providing exceptionally clean copy. If you'd like to get in touch with Erica, stop by a contributors meeting on Monday night in room 312 of the SUB. There'll be pitches, pizza, and a lot of pretty cool people.



Katrina Pyne
News Editor

Ninety-nine per cent coffee and one per cent nervous anxiety makes up Katrina. She may have only entered the journalism program at King's because she'd watched a lot of the *Gilmore Girls* the night before the registration deadline, but she's pretty sure she's in the right field now, she thinks. Born and raised in Kingston, Ontario, she spent the summer as a rural reporter for her hometown paper, mostly taking photos of tractor races and fishing excursions. She is now pleased—no, thrilled—to be taking on the role of news editor at the Gazette after many unpaid late nights working to meet the Gazette deadline over the last two years. She is heading into her third year of journalism at King's doing combined honours with international development studies and apologizes in advance for eating most of the pizza at contributor's meetings.



Torey Ellis
Assistant News Editor

Torey is one of those messy King's-Dal hybrid students, in her third year of a journalism and Canadian studies combined honours program. She comes from southern Ontario (not Toronto, thanks very much) and plans to use that very marketable journalism degree to learn about the other 95 per cent of the country. Most of her time is spent either whittling down that pile of really great books she just hasn't been able to get to yet, or wandering around a certain Barrington St. used bookstore finding even better ones.



Leilani Graham-Laidlaw
Opinions Editor/
Online Editor

Leilani is the opinions editor and the online editor for the Dalhousie Gazette. She likes being busy, and to that effect also works at the CBC, writes for various publications, and is in her final year of a bachelor of journalism honours program at the University of King's College. She can usually be found either buried deep into RSS feeds, anywhere there is lots of coffee, or bouncing around like a magpie after some shiny new story.



Leslie Gallagher
Assistant Arts Editor

Leslie Gallagher is entering her fifth and (hopefully) final year of a combined honours degree in English and creative writing. Last year, she was the entirely overwhelmed editor-in-chief of *Verso*, copy-editor of *Fathom*, and president of the English society. She is also a research assistant with the Editing Modernism in Canada project. Her other interests include dancing (alone), cooking (for other people), and playing hide-and-seek with Winston, her mostly-affable guinea pig.



Jenna Harvie
Creative Editor

Jenna is a writer. She just graduated from the University of King's College with a BA in English and creative writing. She has had the pleasure of seeing multiple poems and short stories published in Halifax and in her hometown of Ottawa. Throughout her four years at King's and Dalhousie she has worked as fiction editor, design editor, and editor-in-chief of *Fathom*; design editor of *Verso*; fiction editor for the *Gazette*; and Copy Editor for *Just*. She also writes for a horror blog where she reviews comics and graphic novels. She is continuing her education at Dalhousie by starting in computer science where she specializes in graphics, gaming and media. Her new career path will help her finish her science fiction novels as well as provide inspiration for the other genres that she writes in.



Ian Froese
Sports Editor

Born and raised in rural Manitoba, Ian is studying journalism at the University of King's College. Before writing sports routinely for the *Gazette* last year, Ian contributed to the student paper at the University of Manitoba. This summer he worked as a reporter/photographer for *The Carillon*, an award-winning weekly newspaper near his hometown.



Angela Gzowski
Photo Editor

Angela Gzowski was born in Yellowknife, NWT. She took her Bachelor of Fine Arts in photography at NSCAD University. She works for *The Coast* as well as a freelance photographer. Check out her work at www.angelagzowski.daportfolio.com and flickr.com/photos/angelagzowski/.



Jonathan Rotsztain
Art Director

Jonathan Rotsztain returns as the *Gazette's* "layout guy" for a second year. He's a freelance graphic designer available to work on your creative projects. Get in touch!

Tomorrow's Professionals Apply Today!

Apply Online!

OMSAS www.ouac.on.ca/omsas/

Ontario Medical School Application Service
September 15, 2011: Last day to create an account for the online application
October 3, 2011: Application deadline



OLSAS www.ouac.on.ca/olsas/

Ontario Law School Application Service
November 1, 2011: Application deadline for first-year English programs
February 1, 2011: Application deadline for first-year French programs
May 1, 2012: Application deadline for upper-year programs

TEAS www.ouac.on.ca/teas/

Teacher Education Application Service
December 1, 2011: Application deadline for English programs
March 1, 2012: Application deadline for French programs



ORPAS www.ouac.on.ca/orpas/

Ontario Rehabilitation Sciences Programs Application Service
(Audiology, Occupational Therapy, Physical Therapy/Physiotherapy, Speech-Language Pathology)
January 6, 2012: Application deadline



ONTARIO UNIVERSITIES' APPLICATION CENTRE
CENTRE DE DEMANDE D'ADMISSION
AUX UNIVERSITÉS DE L'ONTARIO

170 Research Lane
Guelph ON N1G 5E2
www.ouac.on.ca

Advertise in the Gazette!

Contact Aaron Merchant
advertising@dalgazette.com

902 449 7281



STREETEER

It's Orientation Week: SHOW US YOUR O-FACE!

by Ian Froese and Jonathan Rotszain



"OOO"

Katrina Pyne
3rd-year journalism



"OOO"

Nikel Premsagar
3rd-year industrial engineering



"OOO"

Amanda MacDonald
5th-year enviro-engineering



"OOO"

Mike Candlish
1st-year engineering



"OOO"

Shelby Hughes
Transition Year Program



"OOO"

Laura Vingoe-Cram
3rd year theatre



"OOO"

Kamran Rahimian
2nd-year computer science



"OOO"

Danielle Howe
4th-year psychology



"OOO"

Ken Tse
Bachelor mechanical engineering



"OOO"

Elizabeth Wu
2nd-year science

PSEUDIO

Kick-off your school year with the hottest looks of the season.

Whether you're new in town or a Seasonal senior, Pseudio is your #1 Fashion Destination!

With over 23 stores in Atlantic Canada, support local business AND be top of the class in the top styles from:

Bench. **DE** **GUESS** **S**
billabong **Hurley** **SILVER JEANS**
JACK & JONES **THE NORTH FACE** **element**
roxy **Bench.**

Don't forget to check us out on **facebook** for updates, contests & more!

Park Lane Mall • Dartmouth Crossing
Halifax Shopping Centre • Bayer's Lake

OVERHEARD AT DAL

On North Street: "I was just hanging in the Magdalen Islands and I heard a lot of former FLQ-guys are hiding out around there."

Drug Education prof: "How would it feel to be in a burning building filled with 8000 dollars worth of pot plants? Would you even know you were on fire?"

At Pizza Corner: A fellow drunk, pizza eating gentleman comes up to me, starts singing and dancing the Soulja Boi routine. He drops his pizza on the ground, picks it up, shoves it in his mouth and runs away screaming "don't judge me!"



**EAVESDROP/POST:
OVERHEARD AT DAL
FACEBOOK GROUP!
DO IT NOW!!**



Phone
423-2500



Now in your Neighbourhood !

Laptop & Desktop Service

RAM & Hard Drive Upgrades

Virus Removal & OS Reloads

Laptop AC Adapters & More !

University Ave.

Robie St. | IWK | QEII | South St. | South Park St.

South St.

Tower Rd.

centurycomputer.ca 1200 Tower Rd, Suite 101
Halifax, NS

email: jdrisdelle@centurycomputer.ca

Glamour Pig "ANIMALS"



WHEN I WAS LITTLE, THE THINGS I WAS MOST JEALOUS OF WERE KIDS WHO DIDN'T HAVE TO GO TO CHURCH, AND KIDS WHO HAD PETS.



AS I GREW OLDER I WOULD SOMETIMES WORRY THAT BECAUSE I'D NEVER HAD A BIG SLOBBERY DOG TO WRESTLE OR A KITTEN TO PET, MY ABILITIES TO LOVE OR BE JOYOUS MIGHT BE SOMEHOW WANTING.



I WAS ALWAYS DEVSING WAYS TO PROVE MY WORTHINESS.



IN ASSUMING DIFFERENT RESPONSIBILITIES OVER TIME I HAVE THANKFULLY DISCOVERED THAT THIS IS NOT THE CASE.



Fall 2011
Part-Time classes
From September 26th to December 2nd

EVENING COURSES
Offered at 1589 Walnut Street

ONCE A WEEK: 6:30 - 9:00PM
Regular courses:
25 hours of instruction

Beginner 1 - Mon., Tues., Wed. or Thurs.
Beginner 2 - Mon. or Wed.
Beginner 3 - Tues. or Thurs.
Beginner 4 - Tues. or Wed.
Conversation (Beginner) - Wed.
Intermediate 1 - Thurs.
Intermediate 2 - Tues.
Intermediate 3 - Mon.
Intermediate 4 - Tues.
Conversation (Intermediate) - Thurs.
Advanced 1 - Mon.
Advanced 2 - Thurs.
Advanced 3 - Wed.
Advanced 4 - Tues.
Conversation (Advanced) - Mon.
Atelier de français écrit - Mon.

TWICE A WEEK: 6:30-9:00PM
Accelerated courses:
50 hours of instruction

Beginner 3 and 4 - Mon. and Wed.
Intermediate 3 and 4 - Tues. and Thurs.

AFTERNOON COURSES
Offered at 1589 Walnut Street

ONCE A WEEK: 3:45 - 6:15PM

Beginner 3 - Monday
Conversation (Beginner) - Tuesday
Intermediate 3 - Thursday
Advanced 1 - Wednesday

DAY COURSES
Offered at the Atlantic School of Theology on Franklyn Street.

ONCE A WEEK

Beginner 1 - Thursday 9:00 - 11:30AM
Beginner 2 - Tuesday 1:00 - 3:30PM
Beginner 3 - Wednesday 9:00 - 11:30AM
Beginner 4 - Tuesday 9:00 - 11:30AM
Conversation (Beginner) Friday 9:00 - 11:30AM
Intermediate 1 - Wednesday 1:00 - 3:30PM
Intermediate 3 - Friday 1:00 - 3:30PM
Intermediate 4 - Thursday 1:00 - 3:30PM
Advanced 2 - Monday 9:00 - 11:30AM
Advanced 3 - Monday 1:00 - 3:30PM
Atelier de français écrit - Wednesday 9:00 - 11:30AM

LEARN SPANISH

ONCE A WEEK
Spanish - Thursday 3:45 - 6:15PM

For more information
Call us at 902-424-4344 or fls@usainteanne.ca

Halifax Campus:
1589 Walnut Street
Halifax, Nova Scotia B3H 3S1



New students: We will hold 3 Information and Registration nights on September 19th, 20th and 21st between 1:00PM and 7:00PM. Students are asked to come on site to register and undergo a short assessment to determine their level. The whole process usually lasts 30 minutes.

Former students: Students who were enrolled in Spring 2011 or Summer 2011 session do not need to be tested and can register anytime, in person, by phone or by fax.

Cost of classes		
Class type	Early registration (Until Sept. 22 nd)	
Regular	\$215	\$200
Accelerated	\$430	\$400

Payments can be made in person (cash, debit, Visa or Mastercard) by phone (Visa or Mastercard) by calling 902-424-4344 or by fax at 902-424-3607 (Visa or Mastercard).

COMICS WANTED
submit to comics@dalgazette.com

STUDENT SPECIAL
The good life. Made easy.

Join Today!

only **\$309** + tax



GoodLife FITNESS 1-800-597-1FIT
goodlifefitness.com

*When joining you will be required to pay \$309 plus applicable tax. No additional fees are required above the specified membership fee. Must be 18 years of age or older with a valid student ID. Membership expires 8 months from date of purchase. Limited time offer. One club price only. Offer valid at participating clubs only. Other conditions may apply, see club for details.

LIKE US ON

facebook

facebook.com/DalGazette



Erica Eades Arts Editor

Rattle and hum

Local improv collective begins new season at the Bus Stop

Nick Laugher
 Arts Contributor

Outlandishly articulate and fiercely dedicated, Norm Adams is an arbiter of challenging ideas and unbridled sonic experiences. The artistic director for the boundary-pushing improvisation collective, suddenlyLISTEN, and the principle cellist for Symphony Nova Scotia, Adams is vehemently dedicated to discovering and showcasing the obscure, incendiary talents of Canadian improvisational artists.

Deeply mired in preparation for the 11th incarnation of his improvisational concert series, beginning September 15 at the Bus Stop Theatre, Adams is ecstatic about unleashing another year.

"It's a series of concerts I started 11 years ago, dedicated to providing Canadian musicians, especially improvisational musicians, with the opportunity to play and share their music. Each year I kind of agonize over these brilliant artists who I love and respect, trying to unveil their brilliance and set up interesting collaborations," says Adams.

Throwing open the floodgates for 2011 will be a gritty, thunderous wash of cold-blooded bayou beats and murky swamp blues, known, tongue in cheek, as *Hoarse Rattle*.

"I had these two artists in mind to work with," says Adams, "Isaiah Ceccarelli, who's this noisy, rattly, immense drummer and Arthur Bull, who's this savage, dirty, blues guitar player. It will be those two amazing artists, as well as myself on cello, playing a kind of improvisational, jaggedly rhythmic, haunted Louisi-

ania blues thing."

Lauding the talents of his cohorts, Adams is quick to praise both artists for their bold dynamics and eclectic styles.

"Arthur is this immaculate blues guitar player who's been deeply ensconced in the wilderness in Digby Neck for about three years. He does a lot with found objects, where he's manipulating his sound with paper plates and tinfoil. He's got this insane, murky, front-porch blues sound going on. Whereas Isaiah is playing just this one, huge drum. But he makes it sound as if he's playing a thousand-piece percussion set. He's extremely versatile—almost startlingly so."

In addition to the concerts, Adams and suddenlyLISTEN also run artist workshops, starting September 19 and occurring every other Monday night, where they engage and perform with the public to further showcase musicians and elaborate on the concept of improvisational playing.

"It's a really great program," beams Adams. "We've been running these workshops for about six years now and they're always a huge success."

As for the forthcoming concerts in the 2011/2012 calendar year, Adams is anxiously enthusiastic about an even denser collaborative idea the collective will be attempting.

"We wanted to do something crazy this year, kind of push the envelope further. In November we're going to be putting on a show that's a collaboration between improvisational musicians and the Irondale Ensemble, which is a Halifax based theatre group. We're going to attempt to integrate the two in sort of a parallel

narrative, where the music is just as integral and up-front as the acting, in an improvisational performance of Oscar Wilde's *The Picture of Dorian Gray*. It's something I've never done before, and I'm both enthralled and terrified," chuckles Adams.

In preparation for *Hoarse Rattle*, Adams says that little to no rehearsing or planning takes place beforehand, leaving the piece to a spontaneous navigation of the ambiance of the performance and the nuances of its performers.

"It'll be the most sonically exploratory concert this year, a heavy emphasis on sound manipulation," explains Adams, referring to the miasma of avant-garde textures collected by him and his colleagues. "I'm going to be utilizing the body of my cello for some really out-there acoustic percussion things, as well as doing some digital processing of my sound with a couple of programs I've been working with."

Existing predominantly in the realm of ideas, *Hoarse Rattle* will be a very loosely strung-together, off-the-cuff experience.

"We'll jam together two or three times, if we're lucky, but we won't rehearse anything and we'll have forgotten everything by the time we actually perform. That way, you get to feel out the other artists, and immerse yourself in their style and sound without becoming to reliant on parts or pieces. When you go out there and perform it's all based on ideas. You find yourself tapping into this kind of symbiotic, implicit sense of collaboration, without weighing yourself down with ideas of what you 'should' be playing." ☺



Artistic Director of suddenlyLISTEN, Norm Adams. ••• Photo by Angela Gzowski

*A*R*T*S B*R*I*E*F*S*

Bombay Bicycle Club go back to their roots

Following a historic performance at this year's Reading festival, British indie-rockers Bombay Bicycle Club released their new album last week to glowing reviews.

The U.K. four-piece gained popularity in early 2006 by winning an opening slot at London's Virgin Festival through a competition in part with Channel 4. After releasing their debut album, *I Had the Blues But I Shook Them Loose* in 2009, the band made a brief foray into acoustic guitar-rock with their sophomore effort before releasing their new album, *A Different Kind of Fix* on August 30.

Speaking with *BBC 6* last Wednesday, bassist Ed Nash pointed toward an interest in dance music from front-man Jack Steadman as the reason behind the band's new electronic-based sound.

With influences ranging from recent indie-rock hit makers Deerhunter and Panda Bear, *A Different Kind of Fix* offers fans a more in-depth record in comparison to the bare bones guitar rock of their previous releases.

Stephen Malkmus returns

Last week also saw the release of the new solo album by ex-Pavement frontman, Stephen Malkmus and his backing band, the Jicks. *Mirror Traffic* is the fifth album by the 1990s guitar god in the past decade and has him continuing his delivery of wry prose and sunny guitar-pop.

Coming off 2008's mostly forgettable *Real Emotional Trash* and the subsequent Pavement reunion world tour in 2010, *Mirror Traffic* has Malkmus delving into less abstract songwriting and more concise wordplay.

* * *

Jack White's new posse

In stranger music news, Pitchfork.com reports that White Stripes guitarist Jack White has teamed up with the Insane Clown Posse and garage rockers Jeff the Brotherhood to produce a new single.

The unusual team-up came about after ICP member Violent J ran into the fellow Detroit-native in an airport a few months ago. After discussing their careers, the two

decided to join together to record, with one of the motivating factors being the unexpected nature of the collaboration.

GLAAD responds to Tyler, the Creator's VMA win

Speaking of unexpected, at the recent MTV Video Music Awards, Odd Future rapper/producer Tyler, the Creator surprised viewers by winning the best new artist award.

But not everyone was pleased with the 20-year-old artist's growing acclaim. The Gay & Lesbian Alliance Against Defamation (GLAAD) spoke out about the win, citing his rampant use of anti-gay and misogynistic lyrics and Twitter posts. Although he has spoken out about his shock-based rap as being nothing more than experimental narratives, GLAAD felt his win at the VMAs could push a broader acceptance of his hate-speech among fans of his music.

—Matthew Ritchie ☺

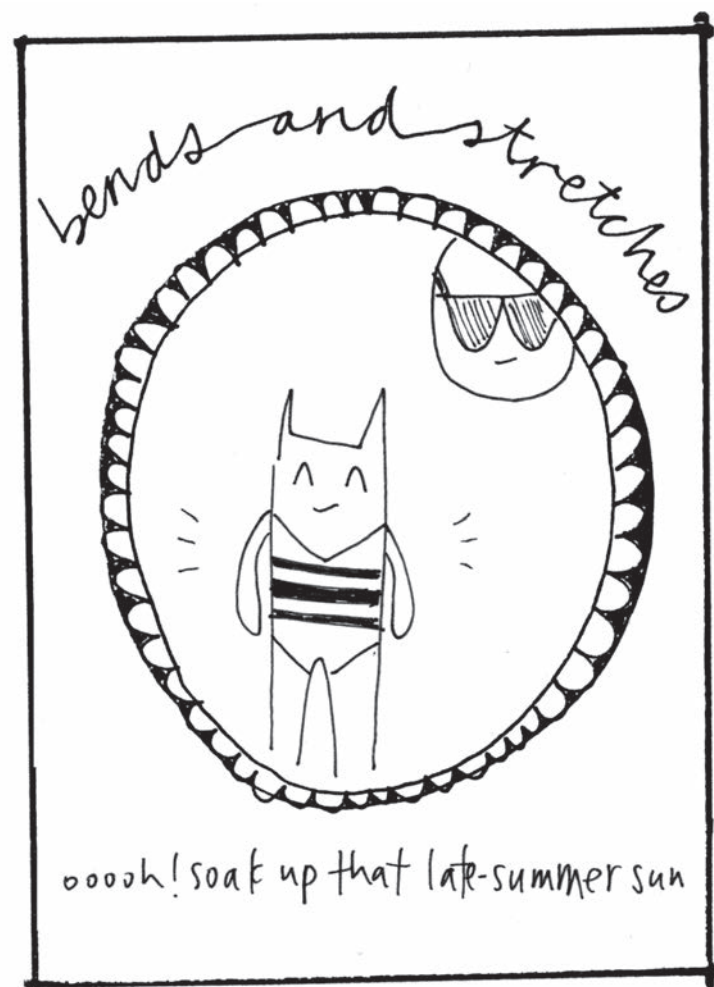

DIY apartment décor (for the not-particularly-crafty)

Rachel Eades
DIY Columnist

Turning a bland apartment or dorm room into a cozy, colourful home can be a challenge when you're on a limited budget and lack the Martha Stewart gene. But here are a few easy projects to brighten up your space that even the most artistically challenged students can handle.

Homemade dry-erase board

Check out any Value Village or thrift store and you'll find stacks of old picture frames for about \$0.50 apiece. Find a reasonably large frame with a glass pane (not plastic). If the frame is wooden, you can repaint it any colour you like with acrylic paint, or if it's still in good condition, you can leave it as-is. Find a sheet of brightly

coloured or patterned scrapbooking paper (any craft store and most discount stores will carry this), cut it to fit in the frame, and then write a heading (such as 'Notes', 'To Do', 'Deadlines') at the top of the page in bold letters. Frame the piece of paper in your new frame, and voila, instant customized dry-erase board! You can also add a calendar grid to your paper for an easy DIY dry-erase calendar.

Free art

The internet is full of free downloadable graphics and cool designs just waiting to be printed out. One great source is www.everythingetsy.com/2011/07/101-pretty-printables-free/, which has literally 101 prints, graphics, and designs you can print for free. Pick up a few more of those \$0.50 Value Village frames we were talking about up above, frame a few of these free prints, and you've got

instant artwork. If you want to give your mismatched frames a more posh look, pick up a can of spray paint at the hardware store for a few bucks, and paint them all to match (remove the glass first!).

Fun with fabric

Another thing that's easy to find at second-hand stores is stacks of fun, colourful squares of fabric (also called "fat quarters"). Pick out a few coordinating pieces of fabric that you like, and then pick out a few embroidery hoops in various sizes (these are also easy to find at second-hand stores). If you're picky about your fabric patterns, you can also pick up fat quarters fairly cheap at fabric stores, where you'll have far more selection. Put a square of fabric into each embroidery hoop, cut off the excess (or tuck it in behind if you're really lazy), and hang them in groups on a blank stretch of

wall. If you're not allowed to put nails in your wall, embroidery hoops are light and thumbtacks will probably do the trick. Or, you can splash out on some of those 3M-brand hooks that stick to the wall, but don't damage the paint.

Thrifty furniture finds

If you're in need of more than decor, Kijiji.com, flea markets, and garage sales are a great way to find cool, unique pieces of furniture for your apartment. A quick search of Kijiji Halifax for furniture with a price limit of \$25 turned up over 1,500 items, including an almost-new leather computer chair for \$20, a free (!) sofa bed in almost perfect condition, a solid wood kitchen table for \$15, and a navy blue La-Z-Boy chair, also for \$15. If you check regularly, you can also find great stuff on the Kijiji free pages (go to kijiji.com and

click 'Free Stuff' in the bottom right corner). Usually the only catch is that you need to pick the item up. Act fast on the free pages though, as the good deals never last long. If your thrifted furniture looks a little drab or mismatched, a couple of bold pillows or an inexpensive throw will go a long way towards brightening them up and making them look coordinated.

And there you have it: a bright and personalized apartment for less than the cost of an IKEA bookshelf! ☺

Rachel Eades is currently living the small-town life with her partner, gardening, cooking, crafting, and generally learning how to live a self-sufficient and thrifty life. When not writing columns, she can be found at diyorsomething.wordpress.com.

Top fall trends on a budget

How to look stylish without cash

Rose Behar
Fashion Columnist

This season's designer looks usher in an urban adult look, replete with a subdued colour palette and clean silhouettes. But if that sounds a little stuffy and expensive to you, don't worry. There'll still be plenty of room to have fun with the trends, even on a student budget.

How? That's where the *Gazette* comes in, with hints and tips on how to pick up the designer look on the cheap.

"Buy good quality and you most likely won't be returning to the mall for a new pair a mere month later in holey, salt-warped monstrosities."

First to tick off the shopping list: this season's bag. The trends call for structure and geometric shapes—a true "ladies" purse. Instead of Prada, try the cut-budget version from Aldo. You can find a wide range of prim and proper handbags from as low as \$30.

Next: the cocktail dress. This style, seen lately on models and movie stars alike, is the simple but sexy white shift. Think sleek, with a high neckline and short hem-line. Trend leader H&M offers some adorable interpretations in the \$40 to \$60 range.

Polka-dot has re-entered the trend cycle this season, becoming the go-to pattern to consider when your outfit lacks a little oomph. Try going vintage with a sheer blouse—we shopped swingfashionista.com to find this little number.

As for shoes and accessories, try out some in the colour of the moment: purple in the plum-burgundy spectrum. Try Spring, Ricki's or any boutique accessory store.

The all essential winter boots—a must-have for every east-coaster—is a great item to splurge on. Buy good quality and you most likely won't be returning to the mall for a new pair a mere month later in holey, salt-warped monstrosities. So keep expectations high and shell out for a stylish, sleek and sexy black leather (or pleather) pair.

The black leather trend has been with us since last season, seeing hugely popular outbreaks of leather items such as skinnies, vests and shorts. At this rate, it looks like it'll be with us a while longer. Jump on board if you haven't already—besides, how can you go wrong with a classic pair of long black boots?

We suggest looking at Aldo, Spring, Payless Shoe Source, or even entering your nearest department store, such as The Bay or Sears, both of which can surprise with high-quality and stylish footwear.

To go along with the boots, snag a jacket made out of another very popular fabric this season: grey wool, in a doctored trench or pea-coat style. If grey wool is in short supply, grey tweed and herringbone are great substitutes.

So go forth and shop, all you shoe-string students out there. Just remember, you don't need tons of money to look fabulous—all you need is a little creative interpretation. ☺

Rose Behar is a second-year journalism student at UKC who loves fashion so much, all she wants to do is write about it.



Nutritious and delicious. ••• Photo by Rob Sangster-Poole

Recipe: Sweet pepper summer salad

Rob Sangster-Poole
Arts Contributor

So, you've just scarfed down a donair, indulged in a few of the Dawgfather's "phat boyz," and pigged out on a meatlover's pizza. Well done, you. But now it's time to diversify your digestive portfolio. Why not try some salad? I know what you're thinking: all that "healthy" stuff mingling in a bowl sans animal carcasses sounds crazy, right? Wrong!

I myself am not a fan of the whole, leafy green salad thing. It brings back too many memories of the sixth grade, when my friends and I would literally eat pages out of our French textbooks to get out of doing homework (and no, this strategy will not work in your first-year calculus class, so don't try). But back to the point—not all salads need to be leafy. So here's an easy recipe with a slight kick that you can really sink your teeth into.

Start by rinsing the black beans and then draining the water. If you have one, a mesh strainer makes this

a bit easier. Then, set aside the beans and start dicing the onion and peppers. The onion adds a nice strong flavour that really makes the salad, but if you're not crazy about it, you can tone down the portions. Once diced, I also like to separate the chunks of red onion with a spoon before adding them, just to get an even distribution. A whole medium-sized red, green and/or yellow pepper will suffice for this recipe. Afterwards, simply mix everything up in a big bowl with the beans.

The dressing is equally easy. Just put everything in a cup or measuring glass and whisk it up. The great thing about this dressing—or any dressing—is that you can always tweak it to suit your tastes. If this recipe is a bit too sweet for you, add a hint of lemon or lime, or even a bit more Dijon to take the edge off. Or if you're feeling bold, throw caution to the wind and add your own little something.

Once you have a flavour you like, pour on as much of the dressing to the salad as you see fit, and voilà! The

best thing about this recipe is that it's cheap. Assuming you have most of the dressing ingredients lying around already, I reckon the rest costs about \$7. For a dish that serves at least four people, that ain't bad. Plus, it's vegan-friendly—kind of. Is honey vegan-friendly? Let's just pretend like it is.

Salad:

1 can of black beans, rinsed
1/2 red onion, diced
1 cup diced red pepper
1 cup diced green pepper
1 cup diced yellow pepper

Dressing:

1/2 cup balsamic vinegar
1/3 cup honey
3-4 tbsp olive oil
2-3 tsp Dijon mustard
1 tbsp ground cumin
1 tbsp ground coriander
1 tbsp fresh basil
Hint of lime or lemon juice (optional)
Salt and pepper to taste ☺

Thrift store vinyl is a dying breed

Mathew Holden
Music Columnist

Twenty years ago records were not cool. They were junk. CDs were where it was at. Vinyl was an obsolete medium, an archaic form of music that filled up shelves in your grandparent's house. No one, except for technophobes and audiophiles, wanted to hold onto their records. CDs were seen as the wave of the future, and they were.

The 8-track had evolved into cassettes, and while cassettes were still common in the 1990s, they were imperfect. They wore out, they got stuck in machines, and most damning of all, they didn't produce the same sound quality as records or CDs. But they had one huge advantage: their size and durability, which made them the first really portable music format. With cassettes came The Sony Walkman, which revolutionized the way people listen to music. Suddenly, it was possible to listen to music anywhere. And so, from the late 1970s to the early 1990s it was common to own both cassettes and records.

The big shift came when CDs became affordable. Sure, it was possible to buy a CD player in the 1980s, but unless you were Patrick Bateman, they were a new luxury far out of the common person's budget.

It was in the early 1990s when everyone made the switch. Like a mass exodus, millions of people left vinyl for the shiny promise of com-

pact discs. This was the record collector's golden age. Every thrift store, flea market and garage sale was overflowing with albums. People couldn't give them away. You could walk into Value Village and buy The Beatles' *Revolver* for a dollar.

Yet like the cassette and the 8-track before it, the CD phenomenon was short-lived. The MP3 format signaled the death of the CD, and as many predicted, the end of paying for music. In a development that few could have predicted, CDs became obsolete, and much quicker than other mediums.

There is no discernible difference between a CD and a high quality computer file. The same cannot be said about a vinyl-to-digital comparison. The problem is that for most vinyl-lovers, there is no definitive answer as to why records sound better. There are technical explanations about compression rates and digital quality loss but usually it comes down to "Vinyl sounds warmer," and arguing that it is the way the artist wanted it to sound. If the music was recorded on all analog equipment (as almost all was until 15 years ago,) it makes sense to listen to it on analog equipment.

Gradually vinyl shifted from being a novelty item, back to big business. CD sales peaked in 2001 and have been steadily declining ever since then, while new vinyl record sales have been growing sharply and steadily ever since. In just three years, vinyl sales almost tripled from

858,000 records sold in 2006 to 2.5 million in 2009.

Musical artists, as well as record stores, must love the growing popularity of physical music. It's something that cannot be downloaded. If you want to listen to the record, you need the record. Unfortunately for people who never stopped buying vinyl, it is now much harder to find anything good in the local thrift store. Gone are the days of heading down to the junk shop to load up on music for a few bucks. Even albums they couldn't give away 10 years ago, Supertramp's *Crime of the Century* for example (a brilliant album at any price), are now considered a lucky find.

For anyone who enjoys the thrill of the hunt, Halifax and Dartmouth have no shortage of Salvation Army and Value Village outlets to waste away the days in. If rummaging isn't your thing, then check out the famous Taz Records (1593 Market St.), or the new Obsolete Records (2454 Agricola St.) for thousands of titles, both new and used. 

Mat is a second-year commerce student from Surrey, BC. When he's not in school, he has been known to wander the world, including long backpacking trips. He collects records and has a newfound obsession with reading classical literature. As well as being a Gazette columnist, he is also the host of CKDU's Needle Vs Groove on Fridays at 10:30 p.m.

.....
"Gone are the days of heading down to the junk shop to load up on music for a few bucks."
.....

••• Photo by Mathew Holden

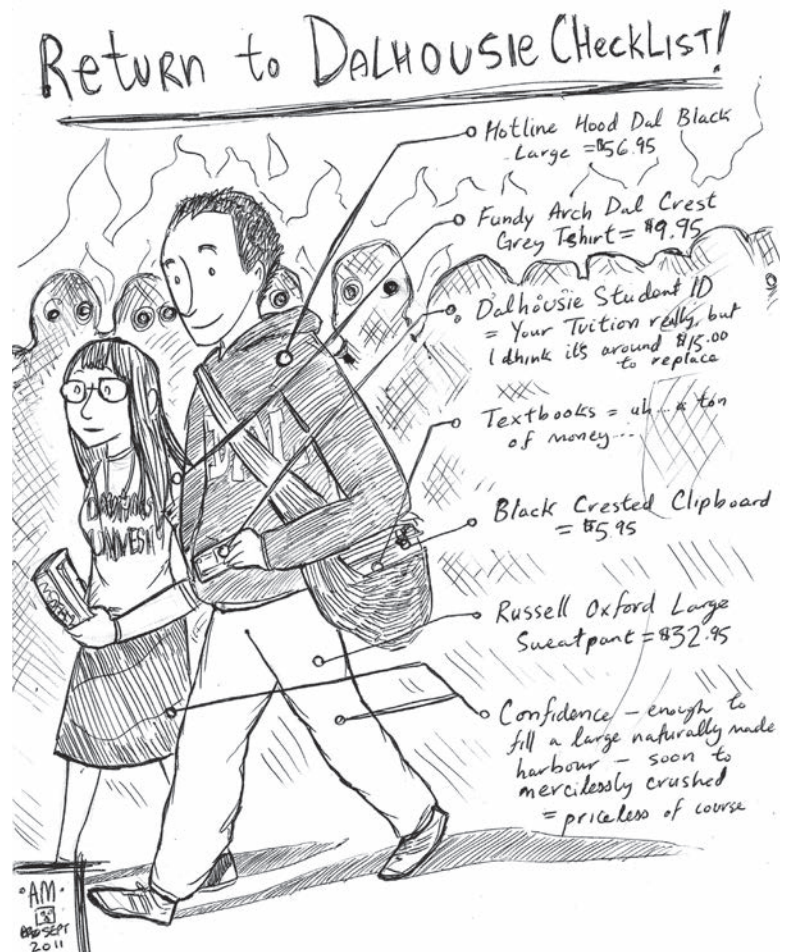
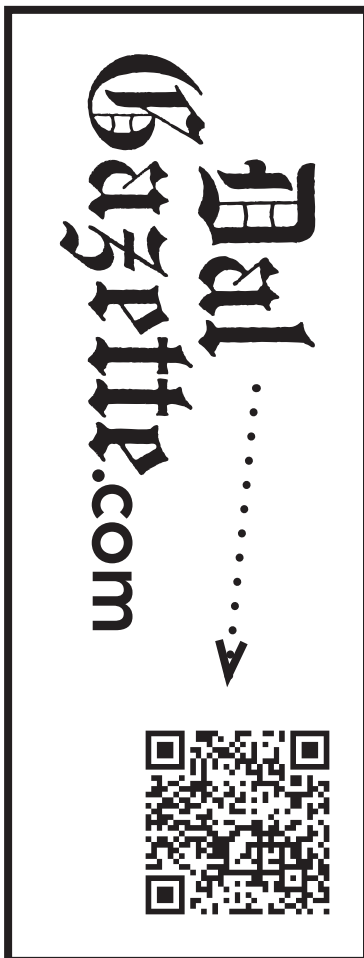
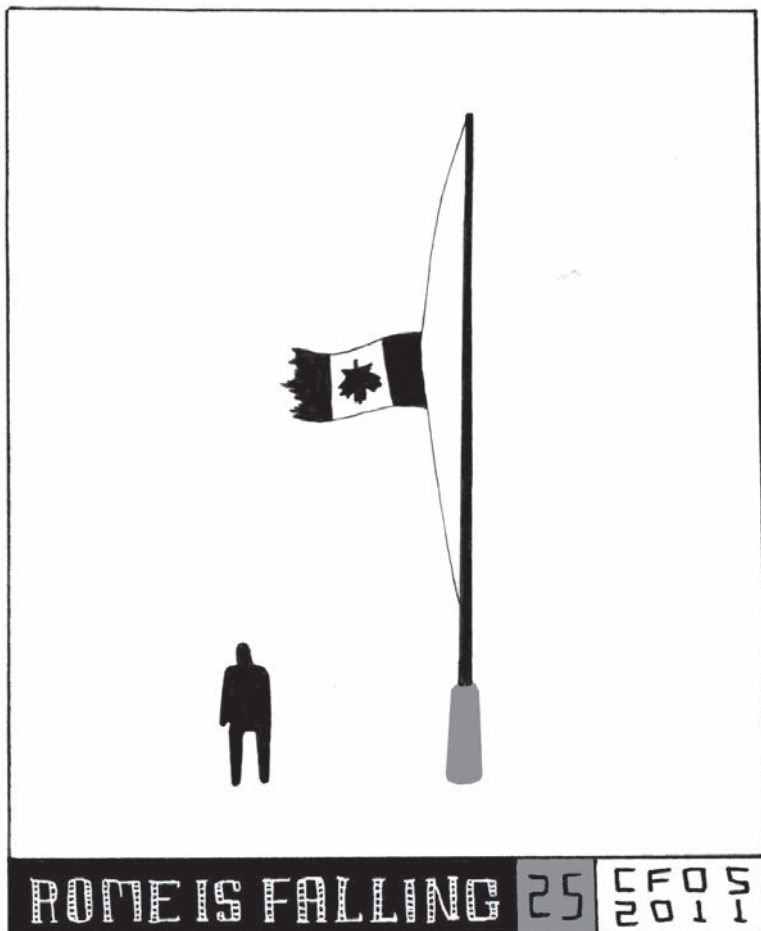



Parking lot evolves into a beach paradise

Halifax hosts successful under-21 beach volleyball championships

Ian Froese
Sports Editor

Beach volleyball on a parking lot? Excuse the skeptic who believed trucking 2,000 tons of sand to the Halifax waterfront to convert a parking lot to host the FIVB Swatch world junior beach volleyball championships seemed like a far-fetched idea. Would local volleyball enthusiasts and casual sports fans alike follow the sand to the Salter Street parking space?

"It's what we hoped. You never really know how people will respond to a first-time event like this, but it all came together," said event director Derek Martin of the under-21 tournament, the first time the tournament has been staged in North America in its 11-year history.

"Having Canada in it has been a fantastic thing for the energy here."

Aside from the qualifying round on Wednesday where entry was free, the 59 teams representing 24 nations played to a strong audience last weekend as a sellout was achieved each day, cramming 2,000 people onto the bleachers at centre court or around the other three courts and two practice facilities.

The atmosphere was tremendous as Canada was in contention for two medals. Attendees waved handheld Canadian fans, chanted and provided

a standing ovation to both Canadian teams following their losing effort.

"With the buzz in the city we would have had good crowds regardless, but having Canada in it has been a fantastic thing for the energy here," said Martin.

Instructed to nurture that fan energy was Adam Hotchkiss, maintaining the MC job he has at Dalhousie volleyball games.

Besides providing basic details to the audience, such as who notched the last kill and which player is next to serve, Hotchkiss was tasked with entertaining the congregation. To this end, he tossed frisbees, encouraged dancing to the music and challenged separate bleachers to a cheering contest.

"The Canada games were pretty easy to get people going. That's the easy part," Hotchkiss said, his voice hoarse from five days of announcing every game at centre court. "The challenge is getting the people interested in the other games."

Hotchkiss, like Martin, was impressed at the number of people that showed up to pack the bleachers. Fans even stood on chairs at the beer gardens to get a better view of the action, or ogled from a hotel roof above.

He credited the large crowd, warm weather and party-like atmosphere with setting the groundwork for a successful weekend. It's a larger-scale formula than what he has been involved with for the past three years with the Dalhousie volleyball teams.

"We have to introduce some of this stuff to a Dal game," Hotchkiss said. "Maybe we could cut open the roof in the Dalplex," he joked. ☺



Above: 59 teams were in play at the under-21 tournament, including Germany; Top Right: Danny Demyanenko of Canada attempts to block the ball against Russia; Bottom Right: Canadian duo Victoria Altomare and Melissa Humana-Paredes lost to the Swiss team in a heartbreaking gold medal match. ••• Photos by Angela Gzowski

Sights from the beach

Ian Froese
Sports Editor

Canadian content

Who knew a northern country like Canada would be a force to be reckoned with in a beach sport?

It may have surprised the Halifax crowd, but they were not complaining Sunday when two Canadian teams fought for the coveted hardware.

Although the two duos were top seeds in their respective divisions, they both faltered in the third and

deciding set of their match.

Toronto-based Victoria Altomare and Melissa Humana-Paredes walked away with a silver medal in the women's division after a late surge could not muster the desired result against eighth-seeded Nina Betschart and Joana Heidrich of Switzerland. The Swiss upset the Canadians in three sets, 21-16, 14-21, 15-11.

Earlier in the afternoon, fellow No. 1 seeds and Toronto residents, Garrett May and Danny Demyanenko could not fend off pesky Brazilians, Marcus Carvalhaes and Vitor Felipe in the men's bronze-medal match.

The South American duo came from behind to hold off a late onslaught and sit on top, 21-23, 21-14, 15-13.

Understandably disheartened at their defeat, the two Canadian teams saluted the crowd after their match, drawing even louder applause from the appreciative 2,000 in attendance.

Corporate synergy

Corporate sponsorship is not out of the ordinary for a national tournament of this magnitude, but nevertheless, their in-your-face presence was overbearing.

Looking out on the boats sailing by

the harbour made for a spectacular backdrop, yet its view was disappointingly congested with a ton of marketing. The beer gardens were filled with umbrellas, hawking some company. Elsewhere there were two inflatable beer bottles and an over-sized volleyball. The athletes even took timeouts huddled around a small table trumpeting another beverage.

I understand this event has to generate funds, but when an array of corporate colours distracts from the inherent beauty of playing volleyball along the waterfront, it's frustrating.

Sex sells

Let's not kid ourselves: an allure of beach volleyball has always been the athletic bodies parading the sands. Just ask those watching the sport on television about the gratuitous shots the camera always manages to find.

As the male athletes walked onto the court to receive their medals, one volunteer moved closer to the players—albeit seemingly out of earshot—and encouraged the men, jokingly, we presume, to hike up their shorts. ☺

Moncton drops out of AFL

Henry Whitfield
Sports Contributor

With just a few weeks before the Atlantic Football League kicks off for another season, the fledgling loop lost a member.

The Moncton Junior Mustangs, situated in a hotbed of football action in recent years as home of an annual CFL regular season game named Touchdown Atlantic, will not compete in the upcoming season citing a player shortage, the league announced last week.

The Junior Mustangs failed to impress last season, unable to pick up a win and being outscored 57 - 157.

The last-minute change, after the schedule was already drawn, means the Dalhousie Tigers will no longer host a contest on Oct. 1. An additional game will be added against UNB Fredericton on a different date. The Tigers will continue to play a six-game regular season.

With Moncton pulling out, the league sits with UNB Fredericton, UNB Saint John and Holland College joining Dal in the four-team circuit.

The AFL began in 2009 with three members before jumping to five teams last season with the inclusion of Dalhousie and Holland College. ☺

Mackinnon and co. may surprise

Mooseheads could be threat next year



John Kushneryk
Sports Contributor

As fans of the now-defunct MLB's Brooklyn Dodgers once put it: "Wait 'til next year!"

The old adage should ring true this season for the Halifax Mooseheads as they attempt to contend for a championship in the QMJHL.

This year's Moose will no lon-

ger be among the league's doormats though—placing fifteenth in the 18-team league last season—courtesy of some significant offseason additions by the front office.

The Moose made the league's biggest splash in the summer break when they acquired first overall draft pick Nathan MacKinnon of Cole Harbour. The forward has already been harkened as the "next Crosby," not solely because of his talent, but

the parallels he shares (same hometown and prep school) with the NHL superstar.

MacKinnon carried Team Nova Scotia at last winter's Canada Games with highlight-reel puck handling and great awareness, but it will be interesting to see where he stacks in a higher-level major junior outfit.

In the draft, a number of weeks before the Mooseheads traded for MacKinnon, Halifax was fortunate enough to swap ahead to second to select forward Jonathan Drouin, a shootout specialist who would have been picked first in any non-MacKinnon year considering his skill level and maturity.

The team also tapped forward Alexandre Grenier, selected 90th overall in the 2011 NHL draft, from the Quebec Remparts. Grenier registered slightly over a point per game in last year's playoffs.

Combined with projected NHL first round picks Martin Frk and Luca Ciampini, the Mooseheads appear loaded on the offensive end, especially considering their nucleus is young—mostly 16- and 17-year-olds.

Their young forward core will have to compensate for the team's recurring issues on the backend. The Moose's defence is slow and neither offensive or defensive-minded.

Of the five returning defensemen, the Herd garnered only 14 goals last season, paced by Konrad Abeltshauser and his eight. Abeltshauser may have been on the scoreboard, but he was dismal in the plus/minus category. He was -36 at the end of the year and -3 in the Herd's four playoff games before the Montreal Juniors swept them.

The goaltending duo in Anthony Terenzio and Fred Piché stood on their heads on some nights, but a combination of poor defensive zone play and bad penalties last season makes it difficult to determine whether they are effective backstops or not. Piché held a respectable 3.13 goals against average after his mid-season acquisition from Saint John, but finished 3-11-3 as the club's top tender.

Much the way the dynasty Oilers of the 1980s rose to prominence with five Stanley Cups, this Mooseheads lineup has the potential to enjoy at least a couple championship-calibre seasons as early as next year. ☺

The Halifax Mooseheads drop the puck on their season Friday in Charlottetown. The Metro Centre should be buzzing next Friday for the home opener against Acadie-Bathurst Titan.

GET INVOLVED, GET ACTIVE AND LIVE WELL @DAL!

Dalhousie University's Department of Athletics and Recreational Services offers Dal students plenty of opportunities to get active, meet up with friends, show your competitive spirit and take your mind off the books! You can also head to Dalplex with your student ID and unwind while staying healthy.

FRIDAY
September 9



Curious about climbing?
Try it for only \$5 in an **Intro To Climbing** session beginning Sunday, Sept. 18. Pre-registration required, call **494-3372**.

SATURDAY
September 10



Get **AMPED** with the Tigers t-shirt giveaway!
W/M Soccer Home Opener vs. UPEI
@ 1/3:15pm

SUNDAY
September 11



W/M Soccer vs. MtA
@ 1/3:15pm

MONDAY
September 12



Connect online with Dalplex and the Dal Tigers on Facebook & Twitter!

TUESDAY
September 13

Join the **Outdoor Adventure Crew's** e-mail list to hear all about the fun outdoor recreation activities taking place through Dalplex!

Email **hreynold@dal.ca** for more info.

WEDNESDAY
September 14

Did you know...if you're a Dal student, **you're already a Dalplex member!** Drop by today with your DalCard and work up a sweat!



THURSDAY
September 15

Sign up for **Kickboxing classes** at Dalplex!

2 classes/per week:
Thu @ 6pm &
Sat @ 12pm.

Dal students: \$145

Pre-registration required, call **494-3372**.

WWW.ATHLETICS.DAL.CA

Dal football anticipates bright future

First impressions favourable at training camp

Henry Whitfield
Sports Contributor

Dalhousie football head coach, Mike Tanner spoke consistently last season about his team needing more size and better athletes, while emphasizing the role of building a strong foundation for the future.

This year's group, Tanner says, more than fits the bill.

"Of course, you can always have bigger bodies, I'd never say no to that. But right now we're 1,000 per

cent better than [we were] this time last year," said Tanner. "We're already miles ahead of last year's training camp, and just looking at the sheer size and athleticism, we're a lot better off."

This summer the Tigers saw 67 players attend their first open tryout, a substantial increase from the 28 attendees last year for the squad's first tryout since its 34-year hiatus.

Training camp, as of last Saturday, boasts four quarterbacks, seven running backs and countless wide-

receivers, a big change from last year when injuries saw players out of position on a regular basis, trying to fill numerous holes in the lineup.

Returnees from last season include standouts Brendan Festeryga and Greg Pelly. Defensive captain and new team president, Bryce Wade will also be back, hoping to push his injury-riddled season behind him and return to full strength.

"Our offence looks to be our strength right now, but it's up to our defence to put in the work and meet

the challenge," said Tanner.

As for the home opener against UNB Saint John, Tanner isn't prepared to make any predictions as the Tigers embark on their six-game regular season.

"We know we can be the better football team. Last year they just pounded the ball down our throats and didn't show much sophistication when they beat us. We like our chances and will continue to push to meet the standard we set last season.

"At the end of the day, we'll have to

see how many 300 pounders show up on the other side of the ball this year." ☎

Dal open their season Sept. 17 against the defending champion UNB Saint John Sea Wolves in a rematch of the 2010 championship. Fans are invited to show up early as a sellout crowd is once again expected. Tickets are available at the Dalplex.

Men's hockey poised to join postseason

Playoff sights set again; last year's berth was first in seven years

Arfa Ayub
Sports Contributor

A season filled with tight losses and nail-biting victories ended in a snap last year when the men's hockey team was knocked from the first round of the playoffs with just 10 seconds remaining in a game they had to win.

Although the end result was disappointing—a two-game sweep to St. FX—the Tigers have shown remarkable improvement over the last two years and appear certain to continue. The team has progressed from collecting just four wins in the 2008-2009 campaign, finishing in last place, to eight during the following year and 13 this past season.

This year the team hopes to move one step closer toward their ultimate goal: winning the AUS championship; a feat the club hasn't accomplished since 1979.

In an effort to end their 33-year streak of futility, head coach Pete Belliveau was busy this summer, adding at least six new hopefuls to their roster. Their most important addition was two-time all-star defenseman David MacDonald, who helped Saint Mary's win the national men's hockey title in 2010. He is leaving his cross-town school to pursue a law degree at Dal.

The talent MacDonald should bring will help Belliveau address one of his team's biggest faults.

"We've always thought he was one of the top two or three defensemen in this league," said Belliveau to the *Halifax Metro* newspaper. "To have him come over to us for a year is huge to help our younger players learn what it takes to win."

Adding experience and leadership to their defensive core, the Tigers are also getting fifth-year transfers Tomas Strynel from the UPEI Panthers and former Acadia Axemen Zach Firlotte. The team has also received a commitment from former Halifax Mooseheads blueliner Pascal Amyot.

Between the pipes, a new recruit, Wendell Vye will fight for the starting position against third-year Bobby Nadeau.

It's only hoped these additions will improve the squad's dismal goals against average of 4.32, second worst in the league last season, and increase their chances of playoff glory.

The Tigers are likely far from legitimately contending for the championship—barely squeaking into the final berth the year before—but if the team keeps improving the way they have, their championship dream may become a reality sooner rather than later. ☎

Dal welcomes St. Thomas for opening night action on Friday, Oct. 14. The Tigers have a six-pack of exhibition games starting in mid-September.



The men's hockey team will be in a tussle for a playoff spot this season. ••• Photo by Abram Gutscher



Juleous Grant is among the returnees on a younger, less experienced Tiger team. ••• Photo by Pau Balite

Younger basketball squad looks to reclaim nationals berth

Armaan Ahluwalia
Sports Contributor

After winning the AUS championship and claiming a sixth place finish at nationals last year, the Tigers roster this upcoming season will miss some of the familiar faces that helped get them there.

Most notably, one of the best university players in the nation last season Simon Farine has graduated and has signed a professional contract with Maccabi Haifa in Israel. As well, Joseph Schow, another graduated Tiger, is playing high-level ball with the semi-professional Medway Park in England. Also leaving Dal are Peter Leighton, a solid three-point shooter, Sandy Veit, a great big man in the paint, and Jason Wang, who was injured for most of last year.

While the Tigers wave goodbye to five athletes, they are also adding four more players: Ritchie Kanza (Mother Teresa High School, Ont.), Derek Norris (John A. McDonald,

N.S.), John Traboulsi (Western High School, Alta.) and Askhat Onov from Russia.

Looking forward to the approaching season, the Tigers have a tough road ahead. Although they are not the only AUS school to have lost plenty of talent, it won't be easy sailing for Dal as they attempt to find leadership in a locker room filled with younger players.

Head coach John Campbell knows this season will be a struggle.

"I think we have a number of players that have played supporting roles in the past that will have the opportunity to establish themselves as major players in our conference. I think our ability to make good decisions offensively and continue to defend well will determine our success."

Expectations for the Tigers might be high after earning a spot in the CIS Final 8 nationals last spring, but fans shouldn't presume they'll see the same team they watched last year. The Tigers will not be as deep as they

once were at the centre or power forward positions, so instead anticipate a guard-heavy offensive team, relying on Casey Fox's game behind the arc. Fox didn't play a game last season, sitting out because he had transferred for Acadia.

Offensive issues aside, the Tigers should retain their strong-suit this year, their defence, particularly with the aid of Stephen Lopez, who will be shutting down some of the league's premier scorers.

The Tigers have a difficult path if they want to make another run at the nationals—held in Halifax for the second consecutive year—but even if they are young, you shouldn't count the Tigers out just yet. ☎

Dal will meet Acadia for their season opener Wednesday, Nov. 9 at the Dalplex. Preseason ball opens in mid-October.

Depression
 Chronic Health Disabilities
 Colitis
 Learning disability
 Quadriplegia
 Bipolar Disorder
 Dyscalculia
 Religious obligations
 ADHD
 Schizophrenia
 Asperger's
 Mental health disability
 Mood Disorders
 Anxiety
 Physical disability
 Diabetes
 Paraplegia
 Autism Spectrum Disorder
 Acquired Brain Injury
 Hearing loss
 Crohn's Disease

Mark A. Hill Accessibility Centre
 Office of Student Accessibility & Accommodation

Ready to help. Visit us today.

dal.ca/studentaccessibility



JOIN US!

CONTRIBUTOR'S MEETINGS

MONDAY SEPTEMBER 12TH, 5:30PM

**ROOM 312, THE SUB
STORIES. PIZZA. COUCHES.**

www.jeansrestaurant.ca
 5972 Spring Garden Road
 Tel 444 7776

**WELCOME
BACK
STUDENTS!**

Eat in, Take Out
ACCEPTED:
DEBIT
 Dal Cards
 Credit Cards
FREE
DELIVERY
 Call for Details

5 YEARS IN A ROW !!!

6th annual **BEST OF FOOD**
 BEST OF THE BEST READERS SURVEY

1st runner up:
 "Best of Chinese restaurant 2007, 2008, 2009, 2010" the Coast

2nd runner up: Best Server +2011

4 STAR
 4 star rating by the Daily News

"good food, cheap, and lots of it!"
 Quote:
 Bill Spurr, Chronicle Herald



THURSDAY, SEPT. 15TH, 2011

GIRL TALK

ALDERNEY LANDING

TICKETS

ONLY \$25
+ FERRY FEE & SERVICE CHARGE

**TIX AVAILABLE
ONLINE AT:
TICKETPRO.CA**

**DOORS AT 7PM
SHOW STARTS
AT 8PM SHARP!**

TICKETS GO ON SALE JULY 15TH, 2011!

